

# aumüller

## Installation and Commissioning Instructions

Power supply according to EN12101-10 and control panel according to prEN12101-9



**SHEV - CONTROL UNIT EMB 7300 - 2,5 A / 5 A / 10 A / 20 A**    **CE**



tested electrical control device EMB 7300  
with recognition number G 514001

01	<p>Abbreviations  Warning and Safety Symbols  Target Groups, Intended Use  Safety Instructions</p>	3 - 6
02	<p><b>2,5 A</b>  <b>5 A</b>  <b>10 A</b>  <b>20 A</b></p> <p>Data sheet SHEV Control Unit EMB 7300 - <b>2,5 A</b>  Data sheet SHEV Control Unit EMB 7300 - <b>5 A</b>  Data sheet SHEV Control Unit EMB 7300 - <b>10 A</b>  Data sheet SHEV Control Unit EMB 7300 - <b>20 A</b></p>	7 - 8
03	<p>Technical Data  Preparing assembly  Connection Facilities / Cabling</p>	9 - 10
04	<p><b>INSTALLATION STEP 1:</b> Connecting drives and ventilation  <b>INSTALLATION STEP 2:</b> Connecting Thermo-Maximal detector in drive line  <b>INSTALLATION STEP 3:</b> Connection of automatic and manual smoke detectors  <b>INSTALLATION STEP 4:</b> Connecting wind and rain sensors</p>	11 - 17
05	<p><b>INSTALLATION STEP 5:</b> Installing relay plug-in card REL and BUS connection  <b>INSTALLATION STEP 6:</b> Connecting power supply</p>	18 - 20
06	<p><b>INSTALLATION STEP 7:</b> System configuration using software „EMB Kompakt“  <b>INSTALLATION STEP 8:</b> Enabling operation / completing installation</p>	21 - 22
07	<p>Troubleshooting and repair, Fuses  Indicator and control elements  Maintenance and Modification</p>	23 - 25
08	<p>Measurement according to EN 60204 / VDE 0113  Storage and dismantling  Warranty and After-Sales Service  Disposal, Liability  Overview on all external connections (to be completed)</p>	26 - 31

## Abbreviations

Index of abbreviations	
These abbreviations are used consistently throughout this instruction. Unless stated differently, all dimensions indicated in this document are in mm. General tolerances in accordance with DIN ISO 2768-m.	
AP	Surface mounting
WxHxD	Width x Height x Depth
CAN	CAN-BUS
CM	Control-Module
COM	Common connection
DIN	German Institute for Standardisation
DM	Drive-Module
EN	European Standard
IN	Input
LON	Local Operating Network
OUT	Output
PG	Price group
PM	Power-Module
PS	Power supply
RM6	Relay-Module
RWA	Smoke and heat exhaust ventilation (SHEV)
SM	Sensor-Module
UP	Flash mounting
WM	Weather-Module
WRG	Wind direction sensor







Colour abbreviation according to IEC 60757					
BK	black	GY	grey	VT	violet
BN	brown	OG	orange	WH	white
BU	blue	PK	pink	YE	yellow
GN	green	RD	red		

Scale units	
°C	Degree Celsius
A	Amperes
Ah	Amp-hours
kg	Kilogram
m	Metres
min	Minutes
mm	Millimetres
s	Seconds
V	Volts
PU	Packaging Units
Vpp	Residual ripple (Voltage Peak-Peak)
W	Watts
Ω / k Ω	Ohm / Kilohms

Figures	
AC	Alternating current (50Hz / 60Hz)
DC	Direct current
I	Electric current
L	Length
ME	Module space unit (1 ME = 23 mm)
NC	Contact „closed“ (normally closed)
NO	Contact „opened“ (normally opened)
P	Electric power
R	Electrical resistance
U	Electric voltage
Um	Change over switch

## Warning and safety symbols in these instructions:

The symbols used in the instructions shall be strictly observed and have the following meaning:

-  **DANGER** Failure to comply with the warning notes results in irreversible injuries or death.
-  **WARNING** Failure to comply with the warning notes can result in irreversible injuries or death.
-  **CAUTION** Failure to comply with the warning notes can result in minor or moderate (reversible) injuries.
-  **NOTE** Failure to comply with the warning notes can lead to damage to property.
-  **Useful note** for an optimum installation.
-  **Note regarding the system configuration** using the free software of the Control Unit manufacturer (USB connection).



**Caution / Warning**  
Danger due to electric current.



**Attention / Warning**  
Risk of damage to / destruction of drives and / or windows.

## Target group

These instructions are intended for personnel trained in electrical engineering and skilled operators of systems for natural smoke ventilation (NRA / SHEV) (natural smoke exhaust system / smoke and heat exhaust system) and natural ventilation via windows, who are knowledgeable of operating modes and remaining risks of the system.



**WARNING**

This device is not intended for use by persons (including children) with physical, sensory or mental limitations or lacking experience and / or knowledge.

## Intended use

### Area of application / Scope of application

This control device is intended for powering and controlling electromotive operated windows in facade and roof areas. **The prime task of this product**, in combination with the electric window, **is to evacuate hot smoke and combustion gases in case of fire** to save human lives and protect property. **Furthermore**, the electric window ensures **fresh air supplied for natural ventilation** of the building.

### Intended use according to the Declaration of Conformity

The control device is intended for stationary installation and electrical connection as part of a building.

In accordance with the attached Declaration of Conformity the control device, in combination with electromotive drives from **AUMÜLLER**, is released for its proper use at a power-operated window:

- Application for natural ventilation
  - with an installation height of the drive and the bottom side of sash of at least 2,5 m above the floor, **or**
  - with an opening width at the HSK of the driven part of < 200 mm by a simultaneous speed of < 15 mm/s at the HSK in closing direction.
- Application as NSHEV (natural smoke and heat exhaust ventilator(s) for ventilation without dual purpose for ventilation in accordance with EN12101-2.

By connecting the window drives with a control device and their operation the builder of the complete system becomes the manufacturer of the power-operated window! If necessary, it is required to perform a risk assessment of the complete system in accordance with the Machinery Directive 2006/42/EG when the utilization or operation of the control device or the connected window drives deviate from their intended use!

**NOTE**

We recommend using exclusively system components by **AUMÜLLER**, because their compatibility is carefully checked in the factory. **AUMÜLLER** shall not assume liability for the system-compatible functioning of third party components. Applications and connections other than explicitly described in these instructions require the express written consent of **AUMÜLLER**. Utilization of applications and components not expressly authorised by **AUMÜLLER** are considered as unintended use even if their perfect functioning is proven at commissioning (e.g. approval under building law).

**NOTE**

## Safety instructions



It is important to follow these instructions for the safety of persons. These instructions must be kept in a safe place for the entire service life of the products.

### Area of application

The control device must be used only for its intended purpose. For additional applications, consult the manufacturer or its authorised dealer.

### Installation

These instructions are intended for expert and safety-conscious electricians and / or qualified personnel familiar with the electrical and mechanical installation of drives and control systems.

### Mounting material

The required mounting material must be modified to fit the occurring load.

### Routing cables and electrical connection

Electrical lines and connections may be routed or installed only by approved specialist contractors. Never operate drives, Control Units, operating elements and sensors at operating voltages and connections contrary to the specifications of the manufacturer.

### NOTE

The planning and calculation of the wiring system is the responsibility of the builder or its agent or the authorised builder and must be performed according to the statutory provisions.

All relevant instructions must be observed for the installation, specifically:

- VDE 0100 Setting up high-voltage systems up to 1000 V
- VDE 0815 Wiring cables
- Specimen Guideline on Conduits German designation (MLAR).



The power line on-site must be secured separately and provided all poles separators. After opening of the system housing voltage carrying parts are exposed. The system must be separated from the power supply and accumulator voltage before each intervention in the Control Unit of the system.

The types of cable, cable lengths and cross-sections must be selected in accordance with the manufacturer's technical data. If necessary, the cable types must be coordinated with the competent local authorities and energy supply companies. Low-voltage lines (24 V DC) must be routed separate from the high-voltage lines. Flexible cables may not be flush-mounted. Freely suspended cables must be equipped with strain reliefs.



Cables must be laid such way that they cannot be sheared off, twisted or bent during operation. It is recommended to perform an insulation measurement of the system's line network and to document this.

Clamping points must be checked for tightness of threaded connections and cable ends. Access to junction boxes, clamping points and external drive control systems must be ensured for maintenance work.

### Commissioning, operation and maintenance

After the installation and after each modification in the set up all functions must be checked with a trial run. After the installation of the system is completed the end-user must be introduced to all important operating steps. If necessary, he must be advised of all remaining risks / dangers.

The end-user must be instructed in intended use of the drives and, if necessary, the safety instructions. The end-user must be specifically instructed that no additional forces, except for the pressure and tension in the opening and closing direction of the casement, may be applied to the spindle, chain or lever of the drive.

### NOTE

Post warning signs!



Before working on the system, it must be completely disconnected from the power supply and emergency power supply (e.g. accumulators) and secured against being switched on again accidentally. While working in the Control Unit the workplace must be secured to prevent unauthorised access. You must ensure that unauthorised personnel are unable to open the Control Unit.

The installation instructions of system components (smoke detector, natural smoke and heat exhaust ventilators, drives, etc.) are part of the documentation for the complete system and must be kept accessible for authorised qualified personnel, together with the installation and operating instructions, for the entire service life of the system.



Check all functions of the system before releasing it for operation.

### Software terms and conditions

The Control Unit is configured by the factory for the intended use (standard configuration). The software, especially developed for this Control Unit, allows a quick and easy adjustment of the factory setting to the respective requirements. Furthermore, the system status can be saved, retrieved and printed.



Modifiable standard configurations are particularly emphasized in these instructions. The software is part of the shipment of the Control Unit. The functional range of this unlicensed version can be expanded by activation against payment (license).

The prerequisites of the system (see chapter "Systems configuration of software") must be checked prior to installation. The "Software clause for handing over the standard software as part of shipments" of the ZVEI (German Electrical and Electronic Manufacturer's Association) is accepted as legally binding upon installation. See our homepage:

**AUMÜLLER AUMATIC GMBH.**  
 (www.aumueller-gmbh.de)



The configuration software of the control device largely excludes damage caused by incorrect settings. As a precaution, we advise that **AUMÜLLER**, as manufacturer, cannot assume liability for damage caused by using **AUMÜLLER** software, because **AUMÜLLER** has no influence on a perfect system environment or property-specific systems configuration.



We, therefore, recommend protecting the operating system and system software sufficiently against unauthorised interference (e.g. by using a password) and attending the training provided by the manufacturer.

**Replacement parts**

System components are to be replaced only with spare parts from the same manufacturer. Liability, warranty and customer service are void if third-party parts are used. Only original spare parts from the manufacturer are to be used for expansions.

**Ambient conditions**

The product may not be subjected to impacts or falls, or to vibrations, moisture, aggressive vapours or other harmful environments, unless the manufacturer has released it for one or more of these environmental conditions.

- **Operation:**  
 Ambient temperature: -5 °C ... +40°C  
 Relative humidity: < 90% up to 20°C;  
                                   < 50% up to 40°C;  
                                   no formation of condensation
- **Transport / Storage:**  
 Storage temperature: 0°C ... +30°C  
 Relative humidity: < 60%

**Accident prevention regulations and employer's liability insurance guidelines**

For work on or in a building or building part the provisions and instructions of the respective accident prevention regulations (UVV and employer's liability insurance guidelines (BGR /ASR) must be observed and obeyed.

**Declaration of Conformity**

The control device is manufactured and inspected for its intended use in accordance with the European guidelines. The relevant Declaration of Conformity is at hand. If the use or operation of the control device or the connected window drives deviate from this a risk assessment must be performed for the complete powered window system and a Declaration of Conformity according to Machinery Directive 2006/42/EG issued as well as a CE labeling obtained.

**Guidelines and Standards**

It is essential that the most recent versions of country-specific laws, regulations, provisions and standards be observed during installation and for electrical connections.

These are for instance:

**State building code** with special construction regulations such as:

- Industrial construction guideline
- Venue regulations, etc.

**MLAR** - Sample Guideline on Conduits German designation

**Provisions of the fire protection authorities TAB (technical connection conditions)**

**for Utility companies**

**German Regulations for Occupational Insurance Schemes**, such as:

- ASR A1.6 and 1.7 (substitute for BGR 232)

**Additional standards and guidelines**, such as:

- EN 60335-2-103** Safety of household and similar electrical appliances
- EN 60730-1** Automatic electrical controls
- EN 12101-10 / prEN 12101-9** (ISO 21927-9/10) Smoke and heat control systems
- DIN 4102-12** Functional integrity of electric cable systems
- VDE 0100** Installation of high-voltage systems up to 1000 V
- VDE 0298** Use of cables
- VDE 0815** Wiring cables (for telecommunication and data processing systems)
- VDE 0833** Alarm systems
- VdS-Guidelines:** 2593, 2581, 2580, 2592

**Accident prevention regulations**, in particular:

- VBG 1 „General rules“ and
- VBG 4 „Electrical systems and equipment“.

For placing on the market, installation and operation outside Germany, the relevant national laws, regulations, standards and safety provisions apply.

The contractor is responsible for proper installation or operation and the issue of a Declaration of Conformity according to European guidelines.

**2,5 A****Data sheet SHEV - Control Unit EMB 7300 - 2,5 A****Feature/Equipment**

- Further settings (e.g. maintenance period) only available with extra cost software license
- Cable entry from above / below / behind
- Optional housing for flash mounting
- Prepared for 2 maintenance-free back-up accumulators **2x 12 V / 2,3 Ah** (Part. No. 541000)

**Application:** Compact Control Unit for smoke and heat exhaust ventilation systems operating with 24V DC voltage, suitable for staircases.

**TECHNICAL DATA (Rated values)**

Operating voltage:	230V AC (195 – 253 V AC, 50/60 Hz)
Max. power consumption:	115 W
Output voltage:	24V DC (20 – 28 V DC / 2 Vpp)
Output current:	<b>2,5 A</b>
Ambient temperature range:	-5°C ... + 40°C
Protection rating:	IP30
Housing:	Surface mounting, steel sheet, RAL 7035 (light grey)
Dimensions (WxHxD):	225 x 285 x 122 mm
Connection terminals:	1,5 mm <sup>2</sup> / drive line: 4 mm <sup>2</sup> (rigid wire)

Motherboard: **1 SHEV group / 1 Vent groups**

**Data sheet SHEV - Control Unit EMB 7300 - 5 A****5 A****Feature/Equipment**

- Further settings (e.g. maintenance period) only available with extra cost software license
- Cable entry from above / below / behind
- Optional housing for flash mounting
- Prepared for 2 maintenance-free back-up accumulators **2x 12 V / 2,3 Ah** (Part. No. 541000)

**Application:** Compact Control Unit for smoke and heat exhaust ventilation systems operating with 24V DC voltage, suitable for staircases.

**TECHNICAL DATA (Rated values)**

Operating voltage:	230V AC (195 – 253 V AC, 50/60 Hz)
Max. power consumption:	460 W
Output voltage:	24V DC (20 – 28 V DC / 0,5 Vpp)
Output current:	<b>5,0 A</b>
Ambient temperature range:	-5°C ... + 40°C
Protection rating:	IP30
Housing:	Surface mounting, steel sheet, RAL 7035 (light grey)
Dimensions (WxHxD):	225 x 285 x 122 mm
Connection terminals:	1,5 mm <sup>2</sup> / Drives: 6 mm <sup>2</sup> (rigid wire)

Motherboard: **1 SHEV group / 1 Vent group**

**Application:** Compact Control Unit for smoke and heat exhaust ventilation systems operating with 24V DC voltage, suitable for staircases.

**TECHNICAL DATA (Rated values)**

Operating voltage:	230V AC (195 – 253 V AC, 50/60 Hz)
Max. power consumption:	460 W
Output voltage:	24V DC (20 – 28 V DC / 0,5 Vpp)
Output current:	<b>5,0 A</b>
Ambient temperature range:	-5°C ... + 40°C
Protection rating:	IP30
Housing:	Surface mounting, steel sheet, RAL 7035 (light grey)
Dimensions (WxHxD):	225 x 285 x 122 mm
Connection terminals:	1,5 mm <sup>2</sup> / Drives: 6 mm <sup>2</sup> (rigid wire)

Motherboard: **1 SHEV group / 2 Vent groups**

**Data sheet SHEV - Control Unit EMB 7300 - 10 A**

**Feature/Equipment**

- Further settings (e.g. maintenance period) only available with extra cost software license
- Cable entry from above / below
- Prepared for **2** maintenance-free backup accumulators **2x 12 V / 7 Ah** (Part. No. 542000)

**Application:** Compact Control Unit for smoke and heat exhaust ventilation systems operating with 24V DC voltage, suitable for staircases.



**TECHNICAL DATA (Rated values)**

Operating voltage:	230V AC (195 – 253 V AC, 50/60 Hz)
Max. power consumption:	506 W
Output voltage:	24V DC (20 – 28 V DC / 0,5 Vpp)
Output current:	<b>10 A</b>
Ambient temperature range:	-5°C ... + 40°C
Protection rating:	IP40
	IP54 with alternatively fixing brackets
Housing:	Surface mounting, steel sheet, RAL 7035 (light grey)
Dimensions (WxHxD):	400 x 300 x 150 mm
Connection terminals:	1,5 mm <sup>2</sup> / Drives: 6 mm <sup>2</sup> (rigid wire)
Motherboard:	<b>1 SHEV group / 1 Vent group</b>

**Application:** Compact Control Unit for smoke and heat exhaust ventilation systems operating with 24V DC voltage, suitable for staircases.



**TECHNICAL DATA (Rated values)**

Operating voltage:	230V AC (195 – 253 V AC, 50/60 Hz)
Max. power consumption:	506 W
Output voltage:	24V DC (20 – 28 V DC / 0,5 Vpp)
Output current:	<b>10 A</b>
Ambient temperature range:	-5°C ... + 40°C
Protection rating:	IP40
	IP54 with alternatively fixing brackets
Housing:	Surface mounting, steel sheet, RAL 7035 (light grey)
Dimensions (WxHxD):	400 x 300 x 150 mm
Connection terminals:	1,5 mm <sup>2</sup> / Drives: 6 mm <sup>2</sup> (rigid wire)
Motherboard:	<b>1 SHEV group / 2 Vent groups</b>

**Data sheet SHEV - Control Unit EMB 7300 - 20 A**

**Feature/Equipment**

- Further settings (e.g. maintenance period) only available with extra cost software license
- Cable entry from above / below
- Prepared for **2** maintenance-free backup accumulators **2x 12 V / 7 Ah** (Part. No. 542000)

**Application:** Compact Control Unit for smoke and heat exhaust ventilation systems operating with 24V DC voltage, suitable for staircases.



**TECHNICAL DATA (Rated values)**

Operating voltage:	230V AC (195 – 253 V AC, 50/60 Hz)
Max. power consumption:	805 W
Output voltage:	24V DC (20 – 28 V DC / 0,5 Vpp)
Output current:	<b>20 A</b>
Ambient temperature range:	-5°C ... + 40°C
Protection rating:	IP40
	IP54 with alternatively fixing brackets
Housing:	Surface mounting, steel sheet, RAL 7035 (light grey)
Dimensions (WxHxD):	400 x 400 x 200 mm
Connection terminals:	1,5 mm <sup>2</sup> / Drives: 6 mm <sup>2</sup> (rigid wire)
Motherboard:	<b>1 SHEV group / 2 Vent groups</b>

## Technical Data

### Electrical data and connected loads

Operating voltage, primary:	195...253 V AC
Frequency:	50...60 Hz
Nominal current (secundär) / Current consumption (primär):	Version 2,5 A / 0,4 A Version 5A / 0,8 A Version 10 A / 1,3 A Version 20 A / 2,6A
Current output (short-time duty): Constant current consumption:	Nominal current 30% max. duty ratio 30 % max. of nominal current (depending on version)
Output voltage, drives: Residual ripple:	24V DC nominal (20...28 V DC) max. 2,0 Vpp (Version 2,5 A) max. 0,5 Vpp (Version 5 A, 10 A, 20 A)
Number of detectors (manual / automatic):	10 units per detector line
Line output:	18...26 V (detector voltage)
Accumulator voltage:	2 x 12 V
Accumulator nominal capacity:	2,3 or 7,0 Ah (depending on version)



The available internal emergency power supply (back-up accumulators), if correctly rated and serviced at regular intervals, ensures that the controller of the Control Unit moves the connected drives open at least twice and close at least once after 72 hours of mains power supply loss.

### Environmental Conditions (operation)

Ambient temperature range:	-5...+40 °C (according to EN 12101 Class 1)
Maximum relative air humidity:	75 % (mean value over lifetime) 90 % (for max. 96 hours)

### Mechanical Data

Surface mounted housing: Protection class:	steel plate painted in RAL 7035 IP 30 (Version 2,5A and 5A) IP 54 (Version 10A and 20A), with wall mounting brackets and seal (not tested).
Housing dimensions (W x H x D): all dimensions given without lock	225 x 285 x 122 mm (Version 2,5A + 5A) 400 x 300 x 150 mm (Version 10A) 400 x 400 x 200 mm (Version 20A)

## Preparing assembly



**Important instructions for safe assembly:** Fully observe all instructions, incorrect assembly may lead to serious injuries.

Before starting the installation please check with the delivery note that the delivery is complete and correct, any complaints received later cannot be considered. It is required to keep a logbook for the EMB 7300 which must be accessible to authorized staff at all times.

### Scope of delivery: SHEV - Control Unit EMB 7300 without break-glass unit in the cover

- Installation and Commissioning Instructions (german and english)
- Test report according to VDE 0113
- Label „Smoke Vent“
- Stickers „ maintenance instructions“
- Drive line end module
- Resistors
- Key

### Scope of delivery: SHEV - Control Unit EMB 7300 with break-glass unit in the cover

- Installation and Commissioning Instructions (german and english)
- Test report according to VDE 0113
- Label „Smoke Vent“
- Stickers „ maintenance instructions“
- Drive line end module
- Resistors
- Key (2 unit)

Connection Facilities / Cabling

2,5 A

5 A

10 A

20 A

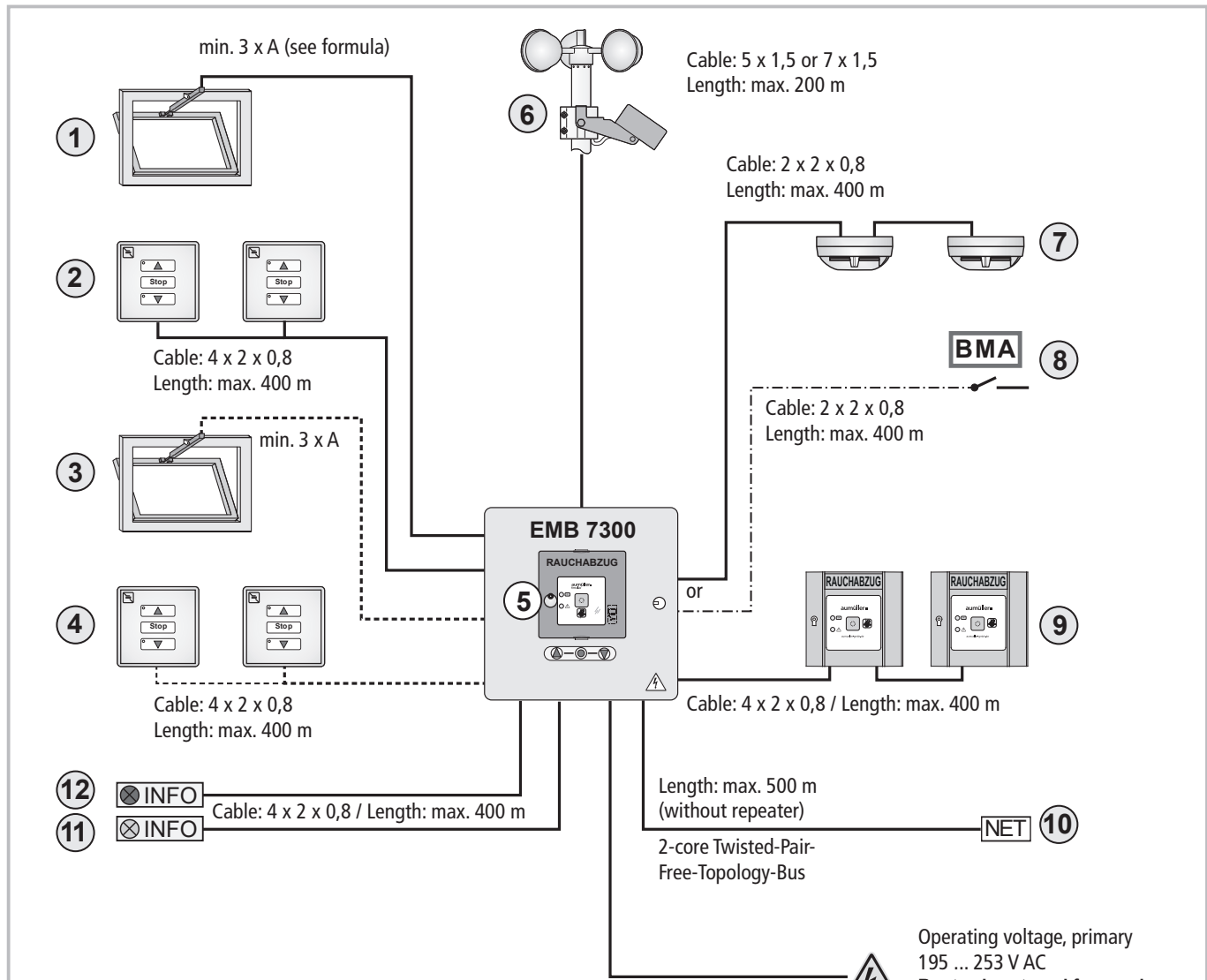

Capiton

- ① Output for drive line 1, 24V DC for smoke + heat exhausting + natural ventilation
  - ② Input for ventilation line 1 (max. 10 vent buttons)
  - ③ Output for drive line 2 (only for EMB 7300 5 A - 0102; 10 A - 0102; 20 A - 0102)
  - ④ Input for ventilation line 2 (max. 10 vent buttons) (only for MB 7300 5 A - 0102 / 10 A - 0102 / 20 A - 0102)
  - ⑤ Housing of Control Unit with or without integrated break-glass unit and ventilation button
  - ⑥ Connections for wind and rain sensor (disabled in case of alarm and power loss)
  - ⑦ Input for smoke detectors (max. 10)
  - ⑧ Input for signal from external fire alarm system (alternative connection)
  - ⑨ Input for break-glass units (HSE - max. 10)
  - ⑩ Port for network integration (requires additional module)
  - ⑪ Output for signal transduction 1 (plug-in module REL65 required) alarm release
  - ⑫ Output for signal transduction 2 (plug-in module REL65 required) collective fault
- only available for EMB 7300 5 A - 0102; 10 A - 0102; 20 A - 0102

These instructions include an overview as support (see chapter „Overview on all external connections to be completed“) for all connection options in which the constructor can record all his connections.

Formula to calculate

the required wire cross-section of a infeed line

$$A \text{ mm}^2 = \frac{I \text{ A} \times L \text{ m} \times 2}{\Delta U \text{ V} \times 56 \text{ m} / (\Omega^* \text{ mm}^2)}$$

- A = cross-section of line in mm<sup>2</sup>
- L = line length in m
- I = current of connected drives in A
- ΔU = line voltage drop = 2 V DC

2,5 A    5 A    10 A    20 A

# INSTALLATION STEP 1: Connecting drives and ventilation



Only connect when disconnected from the mains power supply! Switch off power supply and secure against reconnection!



The system software can:

- of „dead-man mode“ (default) to „self be switched attitude“
- monitoring the drive line will be switched off (standard = on)
- a „automatic closing“ can be set.



Before changing the operating mode check and pay attention to danger zones at the window!



Cable installation must be in compliance with applicable legal requirements. The terminal cross-section for the drive connection is:

EMB 7300	<b>2,5A</b>	-0101	max. 2,5 mm <sup>2</sup> (flexible)
EMB 7300	<b>2,5A</b>	-0101-T	max. 4,0 mm <sup>2</sup> (rigid wire)
EMB 7300	<b>5A</b>	-0101	max. 4,0 mm <sup>2</sup> (flexible)
EMB 7300	<b>5A</b>	-0101-T	or
EMB 7300	<b>5A</b>	-0102	max. 6,0 mm <sup>2</sup> (rigid wire)
EMB 7300	<b>10A</b>	-0101	
EMB 7300	<b>10A</b>	-0102	
EMB 7300	<b>20A</b>	-0102	

Line length and cross-section A (drives) depend on the type of drive and on the number of drives. Line length and cross-section can be determined according to the following formula:

**Formula to calculate**  
the required wire cross-section of a infeed line

$$A \text{ mm}^2 = \frac{I A_{(total)} \times L_m \text{ (length infeed line)} \times 2}{\Delta U V \text{ (voltage drop)} \times 56 \text{ m} / (\Omega \cdot \text{mm}^2)}$$

A = cross-section of line in mm<sup>2</sup>  
L = line length in m  
I = current of connected drives in A  
ΔU = line voltage drop = 2 V DC



The drive line is monitored by drive line end module for line break and short circuit.

## Connecting drives and ventilation: Version EMB 7300 2,5A-0101, EMB 7300 2,5A-0101-T

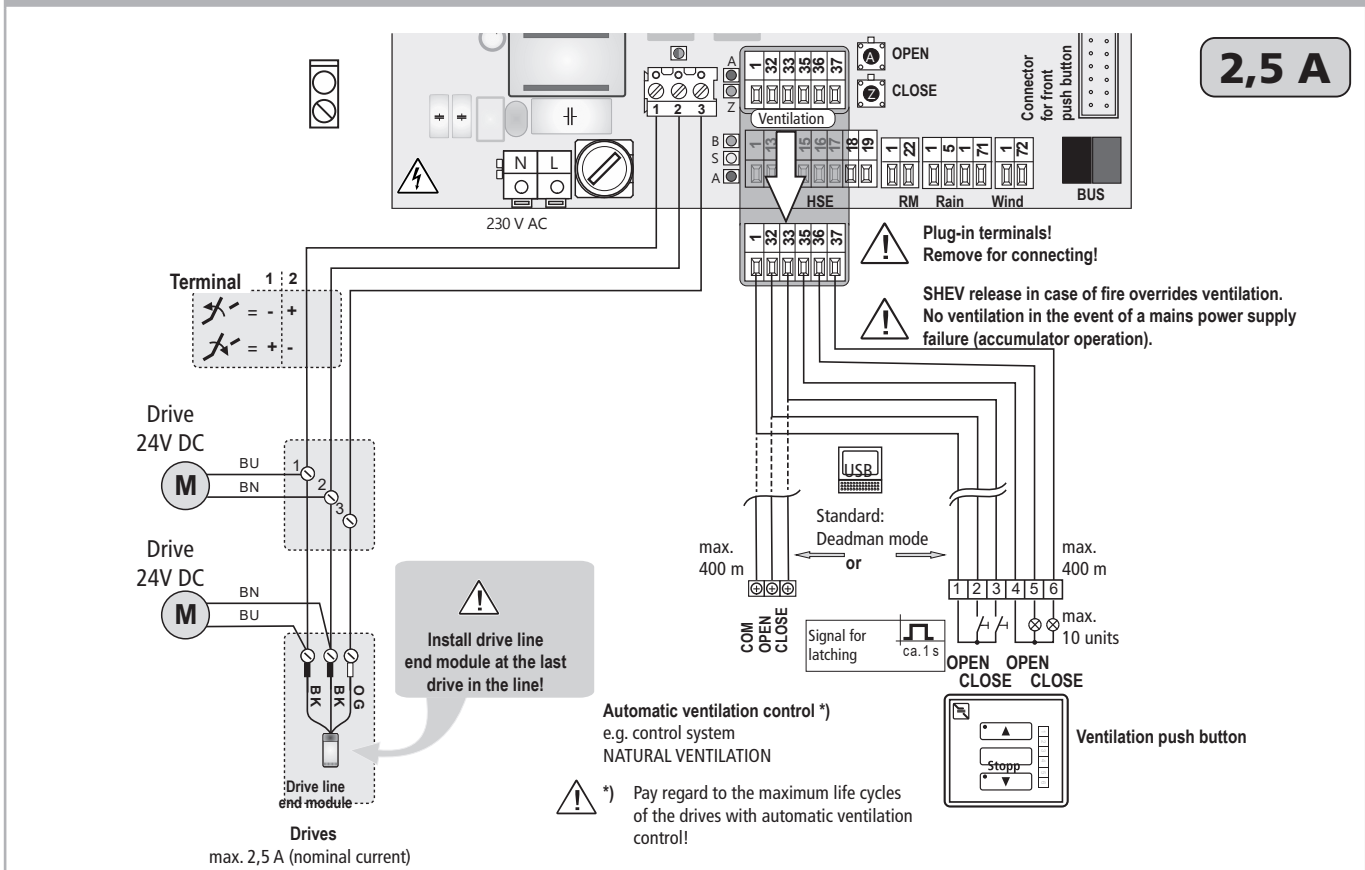

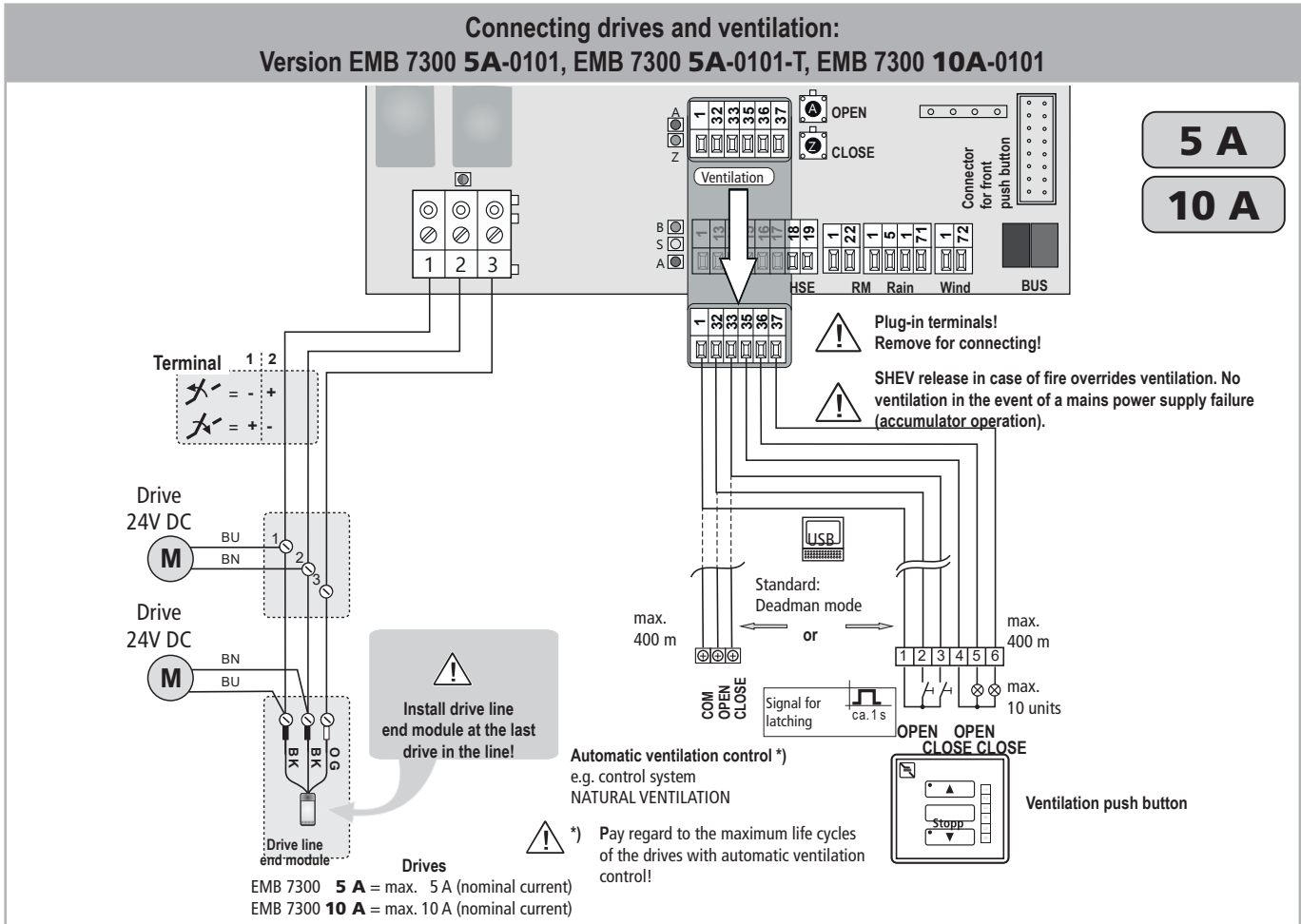

**5 A**  
**10 A**

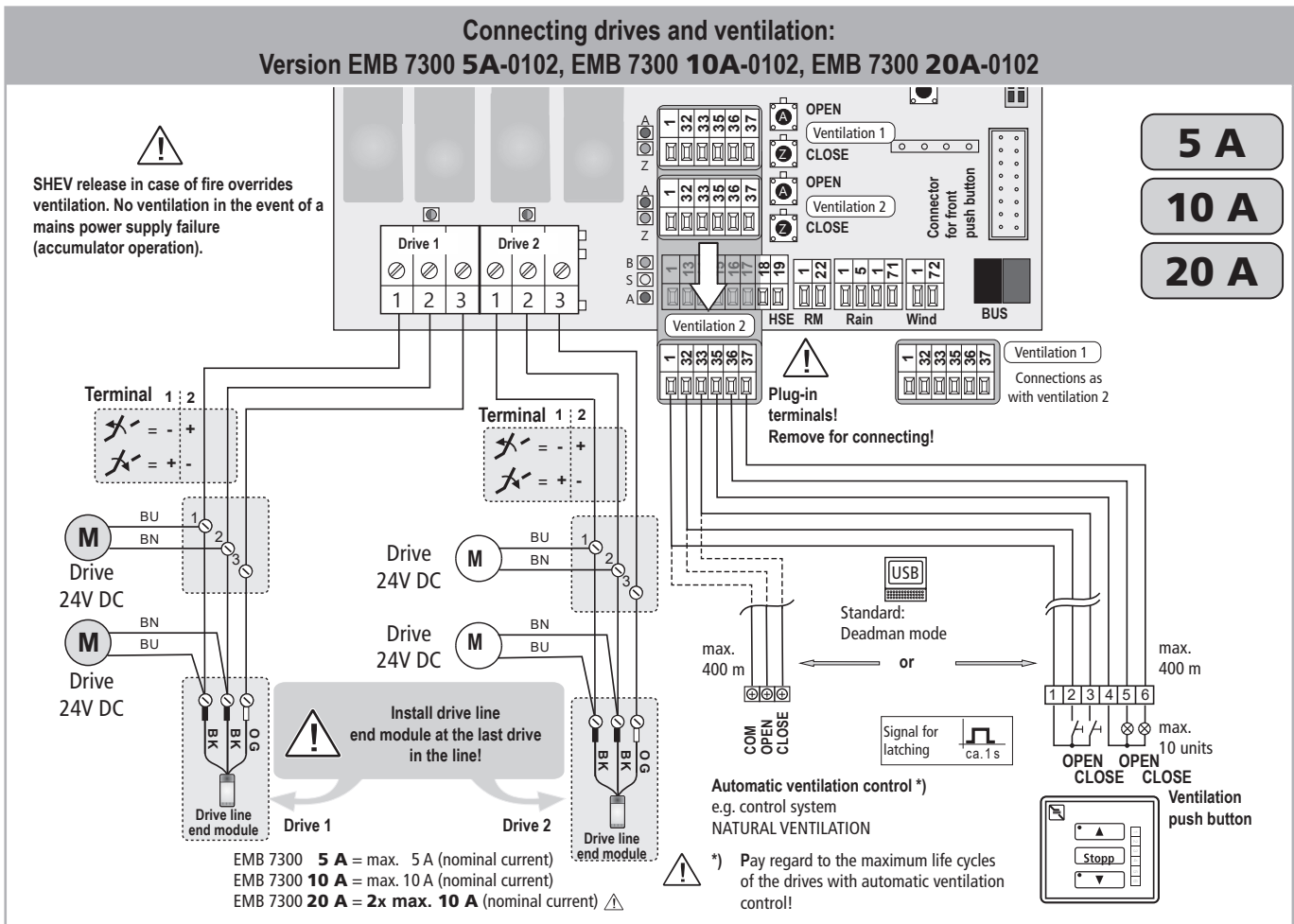

**5 A**  
**10 A**  
**20 A**

2,5 A 5 A  
10 A 20 A

## INSTALLATION STEP 2: Connecting Thermo-Maximal detector (head sensitive fire detector) in drive line



Only connect when disconnected from the mains power supply! Switch off power supply and secure against reconnection!

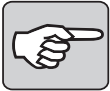

If the drive line is not correctly terminated with an end line module for line monitoring or if the fixed temperature heat detector is incorrectly connected, the yellow fault indicator „S“ will signal a fault after a short while, unless line monitoring was disabled via the licensed software.

If the line monitoring via the licensed software disabled, no fault displayed .

Cable installation must be in compliance with applicable legal requirements. The terminal cross-section for the drive connection is:



EMB 7300	<b>2,5A</b> -0101	max. 2,5 mm <sup>2</sup> (flexible)
EMB 7300	<b>2,5A</b> -0101-T	max. 4,0 mm <sup>2</sup> (rigid wire)
EMB 7300	<b>5A</b> -0101	max. 4,0 mm <sup>2</sup> (flexible)
EMB 7300	<b>5A</b> -0101-T	or
EMB 7300	<b>5A</b> -0102	max. 6,0 mm <sup>2</sup> (rigid wire)
EMB 7300	<b>10A</b> -0101	
EMB 7300	<b>10A</b> -0102	
EMB 7300	<b>20A</b> -0102	

Line length and cross-section A (drives) depend on the type of drive and on the number of drives. Line length and cross-section can be determined according to the following formula:

**Formula to calculate**  
the required wire cross-section of a infeed line

$$A \text{ mm}^2 = \frac{I A_{\text{(total)}} \times L \text{ m (length infeed line)} \times 2}{\Delta U \text{ V (voltage drop)} \times 56 \text{ m / } (\Omega \cdot \text{mm}^2)}$$

A = cross-section of line in mm<sup>2</sup>  
L = line length in m  
I = current of connected drives in A  
ΔU = line voltage drop = 2 V DC



For this trigger method is a software programming required.

### Connecting Thermo-Maximal detectors in drive line

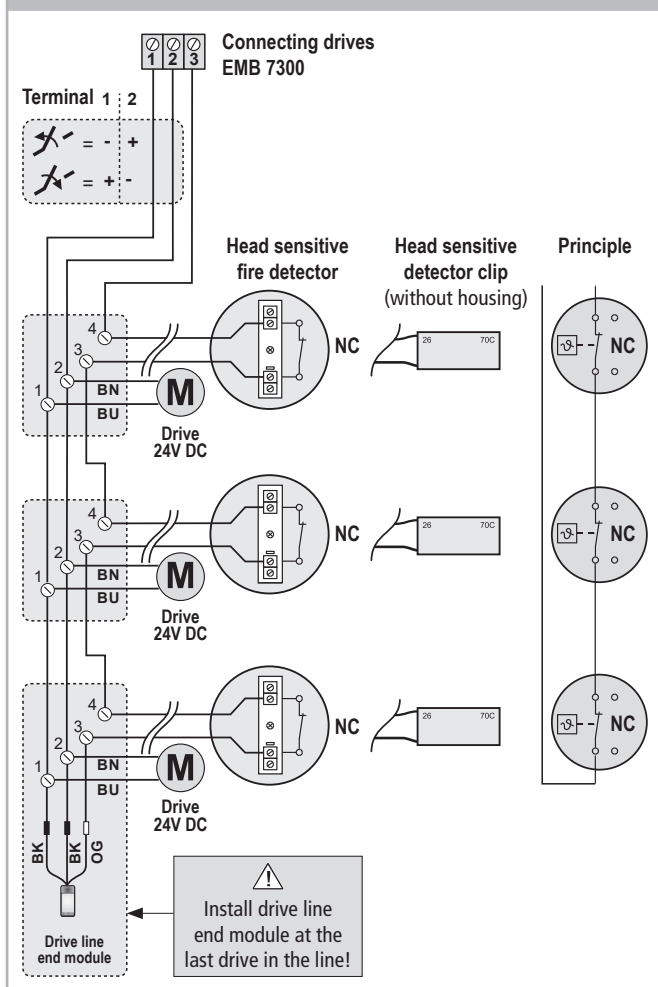

### Compressed gas generator

If the **compressed gas generator function** has been parameterized, the motor line is kept switched off until one of the detector lines is triggered.

After triggering, the motor line is switched in the OPEN direction for an adjustable time (10 s standard, if set to „0“: permanent contact).

#### Test mode (only for mains operation):

The **ventilation button** belonging to the motor line can use the test mode activate (OPEN button, OPEN button display flashes quickly) and deactivate (CLOSE button, OPEN button display goes off again). In test mode, if one of the detector lines is triggered, only the **emergency OPEN LED** is switched on; the motors are not switched.

#### Using motor line monitoring:

If the motor line monitoring is activated (standard), a line break leads to tripping and a **fault display**.

For this monitoring to function as intended, the **compressed gas generator line** must be connected as follows.

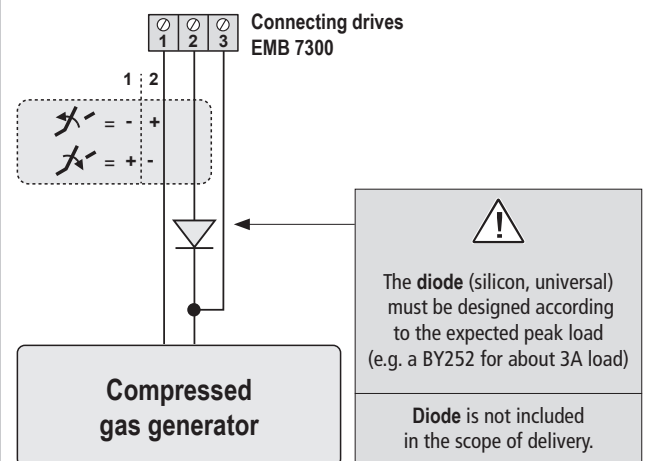



HSE (Break-glass unit) without DIP switches

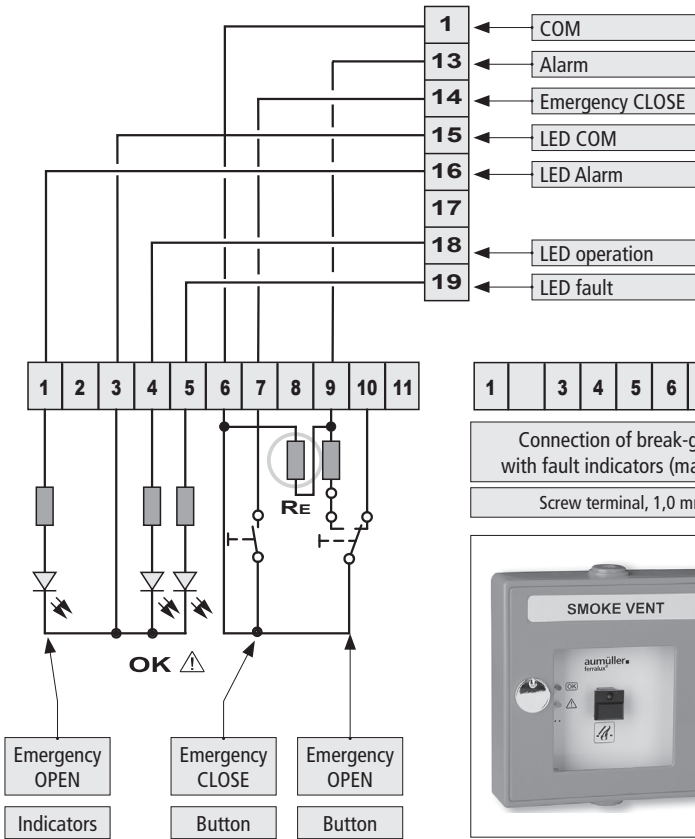

**RE** Resistor  $R_E$  must remain within the last or only break-glass unit.  
Resistors  $R_E$  must always be removed from intermediate break-glass unit (HSE)!

**DIP switches only in version: HSE buzzer**  
**ON 1** buzzer in case of fault      **ON**  
**ON 2** buzzer in case of alarm      **ON**  
**ON 1** buzzer in case of fault      **OFF**  
**ON 2** buzzer in case of alarm      **OFF**

1 3 4 5 6 7 9  
 Connection of break-glass unit **HSE** with fault indicators (main control panel)  
 Screw terminal, 1,0 mm<sup>2</sup> (rigid wire)

1 3 6 9  
 Connection of break-glass unit **HSE N** (secondary control panel)  
 Screw terminal, 1,0 mm<sup>2</sup> (rigid wire)



**Terminal**  
 1 Indicators „emergency OPEN“, 24 V DC  
 3 Connection of return circuit (-) indicators  
 4 Indicators „operation“, 24 V DC  
 5 Indicators „fault“, 24 V DC  
 6 Connection of return circuit (-) button  
 7 Button „CLOSE“ (closer), 24 V DC, 10 mA  
 9 Button „emergency OPEN“ (closer), 24 V DC, 10 mA  
 10 Button „emergency OPEN“ (opener), 24 V DC, 10 mA

HSE (Break-glass unit) with DIP switches

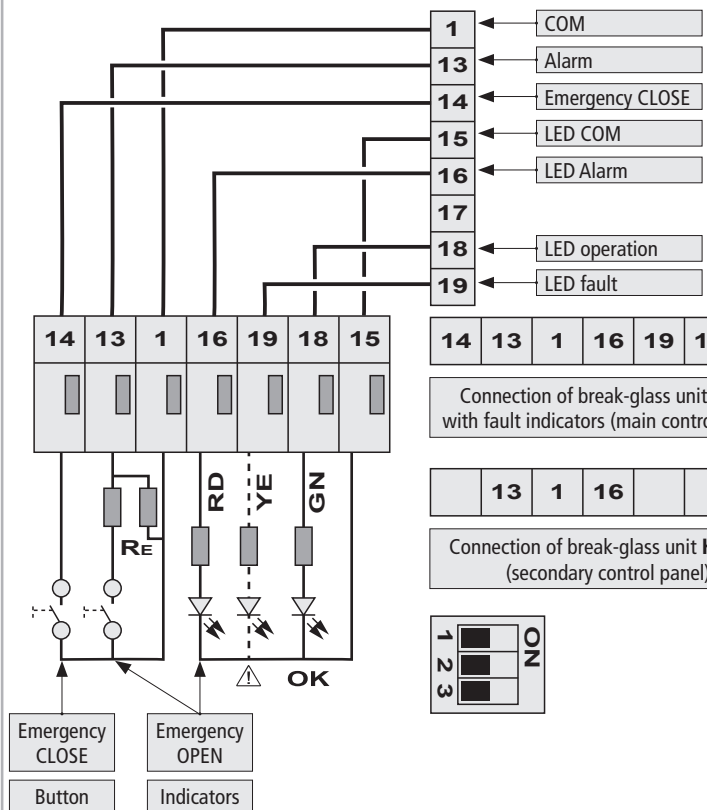

**Terminal**  
 14 Button „CLOSE“ (closer), 24 V DC, 10 mA  
 13 Button „emergency OPEN“ (closer), 24 V DC, 10 mA  
 1 Connection of return circuit (-) button  
 16 Indicators „emergency OPEN“, 24 V DC  
 19 Indicators „fault“, 24 V DC  
 18 Indicators „operation“, 24 V DC  
 15 Connection of return circuit (-) indicators

14 13 1 16 19 18 15  
 Connection of break-glass unit **HSE** with fault indicators (main control panel)  
 Spring terminals, 0,5 mm<sup>2</sup> (rigid wire)

13 1 16 15  
 Connection of break-glass unit **HSE N** (secondary control panel)  
 Spring terminals, 0,5 mm<sup>2</sup> (rigid wire)



**DIP 1** termination resistance switch in the last or only detector.  
**DIP 2** only in version „with buzzer“ in case of fault  
**DIP 3** only in version „with buzzer“ in case of alarm

Connection: HSE - Break-glass unit

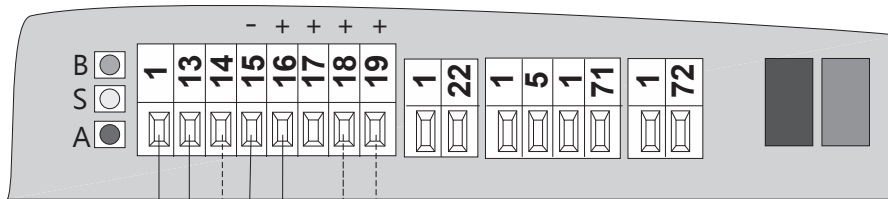
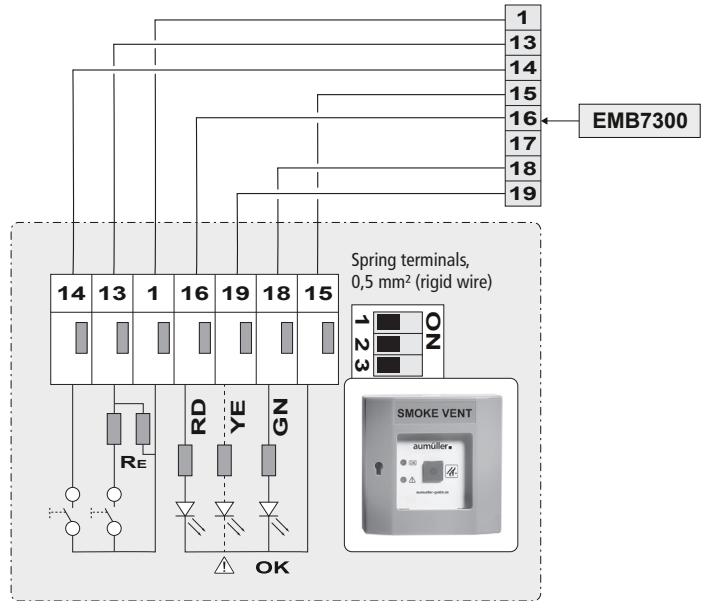
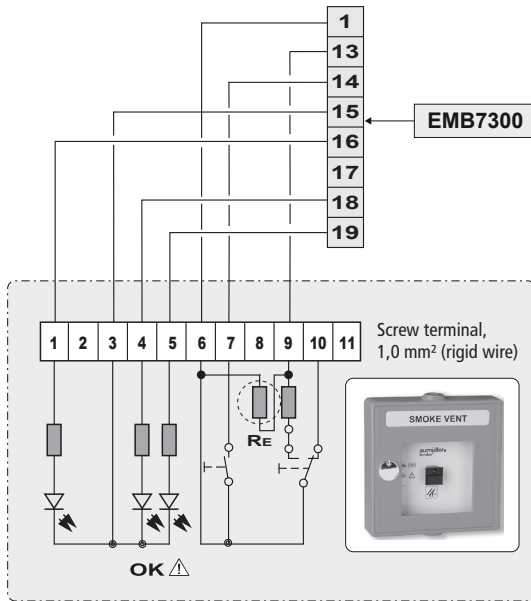

⚠ Resistor  $R_E$  must remain within the last or only break-glass unit.  
Resistors  $R_E$  must always be removed from intermediate break-glass unit (HSE)!

⚠ --- not for secondary control device

⚠ DIP 1 switch on in the last or only detector.

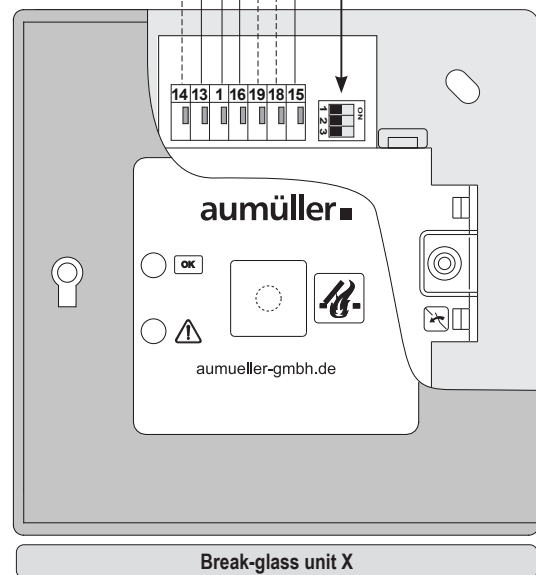
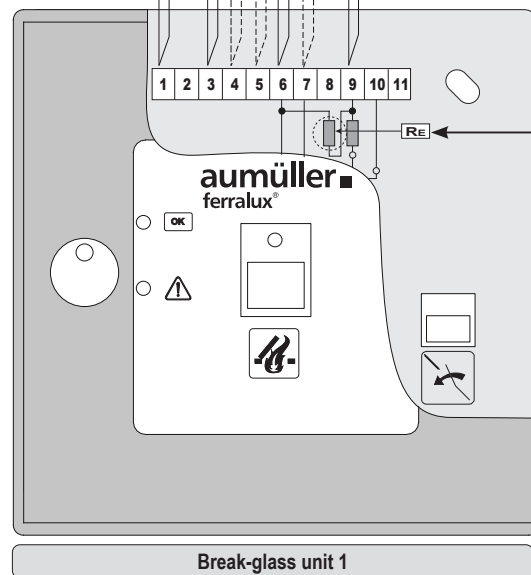

2,5 A 5 A 10 A 20 A

### INSTALLATION STEP 4: Connecting wind and rain sensors



Only connect when disconnected from the mains power supply! Switch off power supply and secure against reconnection!



The system software offers the option to adapt the response threshold of the wind sensor to the local conditions. The factory default setting is 5 m/s. Further modifications of the standard configuration require a paid licence for the software.



Cable installation must be in compliance with applicable legal requirements. The terminal cross section for the rain sensor must be minimum 1,5 mm<sup>2</sup>, for the wind sensor minimum 0,5 mm<sup>2</sup>.

In case of fire (Emergency-OPEN) or failure of power supply (accumulator operation) the ventilation control via wind and rain sensors is deactivated.



Before mounting and positioning the wind/rain sensors carefully read the safety and assembly instructions provided with the products. They are part of the system documentation and must be adhered to and kept accordingly (e.g. for servicing purposes).

#### Connecting wind and rain sensors

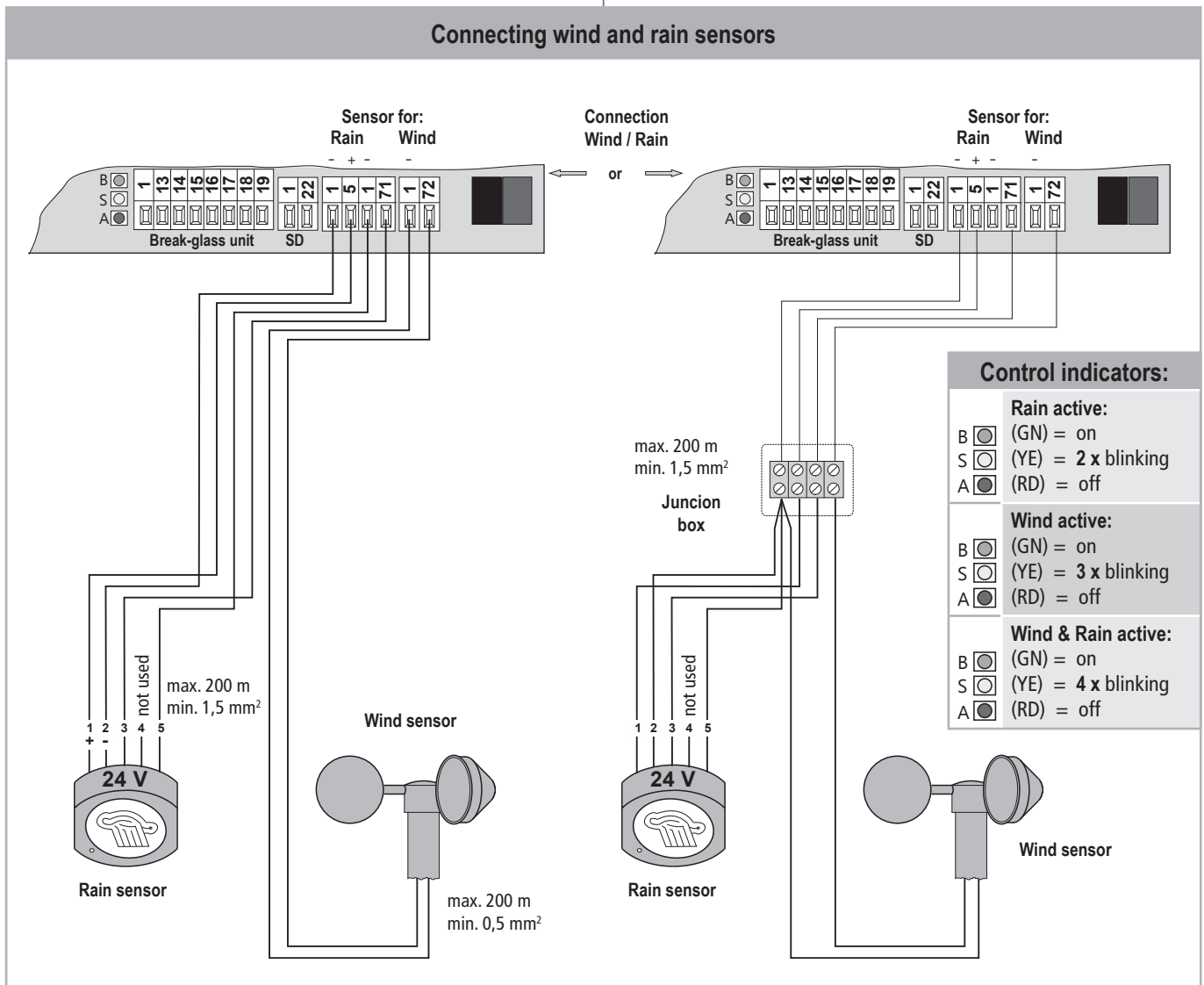

2,5 A

5 A

10 A

20 A

## INSTALLATION STEP 5: Installing relay plug-in card REL and BUS connection



Only installation and connect when disconnected from the mains power supply! Switch off power supply and secure against reconnection!



The motherboard has two slots for using one relay plug-in card REL 65 each (order no. 650200) so that external processing of messages via floating relay contact (1 x change-over switch, max. 30 V / 2A) is possible.

Cable installation must be in compliance with applicable legal requirements. The terminal cross section must be min. 0,5 mm<sup>2</sup> (max. 1,5 mm<sup>2</sup>). The line length is max. 400 m.

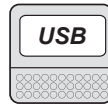

The function of the relay plug-in cards is factory-set:

1. REL 65 = alarm activation / Emergency-OPEN
2. REL 65 = common alarm

Any modification of these standard settings requires a paid licence for the software. Network integration also requires paid activation of the software.

### Installation and exchange of relay plug-in card:

Please proceed as follows:

1. First disconnect Control Unit from mains and accumulator voltage.
2. Carefully insert plug-in card in correct direction.
3. Once correctly inserted, reconnect supply voltage and check for functionality

### Installing relay plug-in card REL and BUS connection

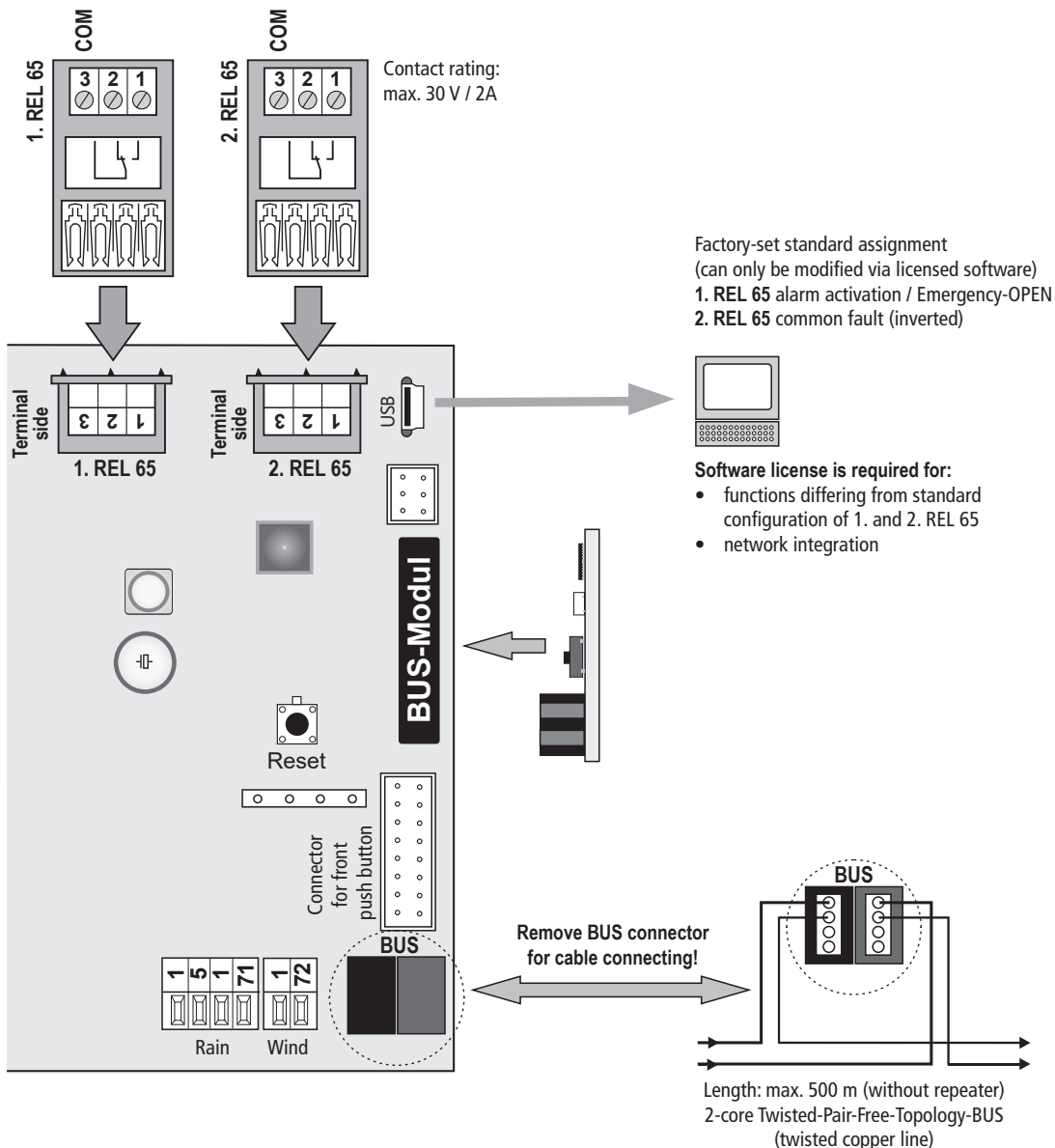

## INSTALLATION STEP 6: Connecting power supply

2,5 A 5 A 10 A 20 A



Route line voltage supply via external fuse and switching component. Only connect supply voltage and accumulator set when disconnected from the mains power supply! Switch off power supply and secure against reconnection!



The system software includes the option to activate the automatic closing feature in the event of a power failure (standard = „no“).



It is essential to ensure correct polarity when connecting the accumulator set! Incorrectly connected accumulators will cause damage to the controller!

### Attachment of the accumulators with the optional accumulator holder set (Part.-No.: 683250) only for compact housing 2,5 A 5 A

The accumulator set may also be fastened to the housing with the optional accumulator holder set.

#### Mounting the accumulator holder set:

- Press 2 x (right and left) plastic screw-plug ① into the squares on the rear side of the housing.
- Fasten bracket ③ with screw ② in screw-plug ① on the right and on the left.

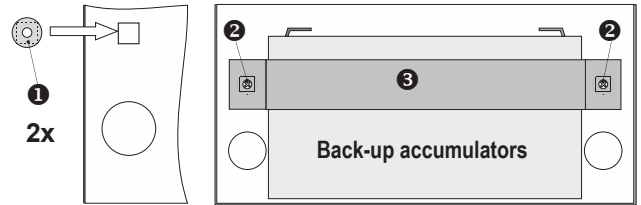

#### Accumulator holder set

	Part.-No.:	683250
	Material:	Steel
	Colour:	RAL 9016 (white)
	Suitable for:	EMB 7300 2,5 A EMB 7300 5 A

### Connecting power supply: Version EMB 7300 2,5A-0101, EMB 7300 2,5A-0101-T

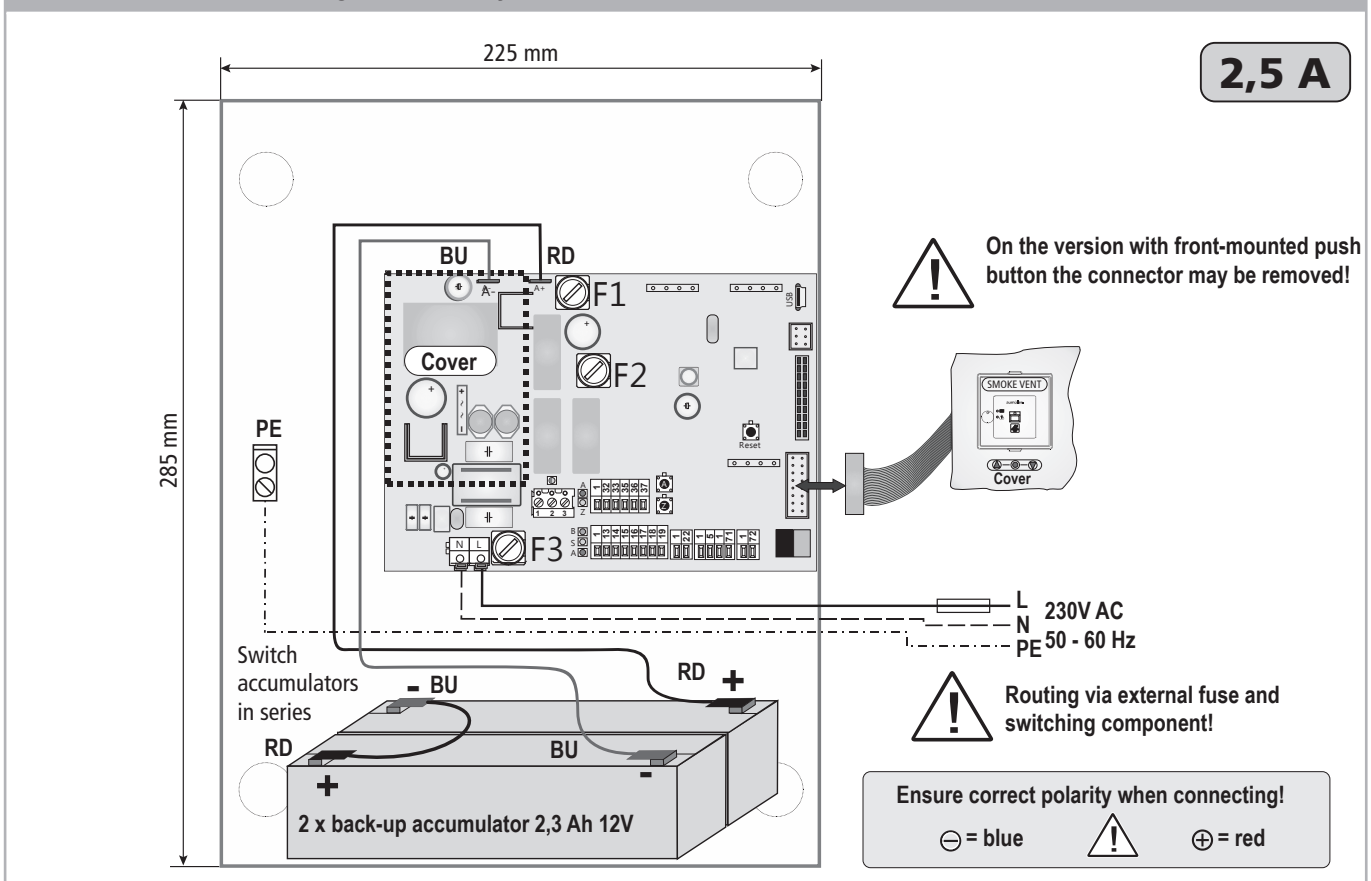

2,5 A



2,5 A 5 A 10 A 20 A

## INSTALLATION STEP 7: System configuration using software: EMB Kompakt

### Installation

A free version of the system software (**version VIEW**) can be downloaded from the homepage [www.aumueller-gmbh.de](http://www.aumueller-gmbh.de). The software can be installed on a computer (notebook or net-book). Please pay regard to the hardware and system requirements (see below).

Follow the instructions displayed on the screen to install the program.



The software offers many features to adapt the system to your requirements. However, you should be aware that not all possible functions can be used without activating the software by purchasing a license.

If you wish to unlock the software, please contact us for a license code. After this code has been entered, you can use the paid functions as well.



With the installation the „Software clause in respect of the licensing of standard software as part of deliveries“ set out by the ZVEI (Zentralverband Elektrotechnik- und Elektronikindustrie e.V. - Central Association of the German Electrical and Electronics Industry) is deemed to be legally binding.

### System Requirements

The software can be installed on a portable computer that has to meet the following system requirements:

<b>CPU:</b> 1 GHz or faster.
<b>Operating systems:</b> Microsoft® Windows 7 - (64 Bit) Microsoft® Windows 10 - (64 Bit)
<b>Memory:</b> 512 MB RAM or more
<b>Hard disk:</b> at least 100 MB free memory space required
<b>Accessories:</b> USB connection for connecting computer<->Control Unit, Internet connection for system installation and updates.



Our software requires NET 2.0 Runtime™ and the Visual C 2008™ Redistribution-Package for operation. These packages will be automatically installed by the set-up program without express installation note if they are not available in the system.

### Connecting the computer with the Control Unit

- Switch on the computer and
- connect via USB to the Control Unit (see illustration).
- Then start the computer with the software already installed.



To avoid data losses the USB cable should not be longer than 5 meters. We advise against using a USB hub. Different to the usual USB connections it does not show up on the Windows toolbar

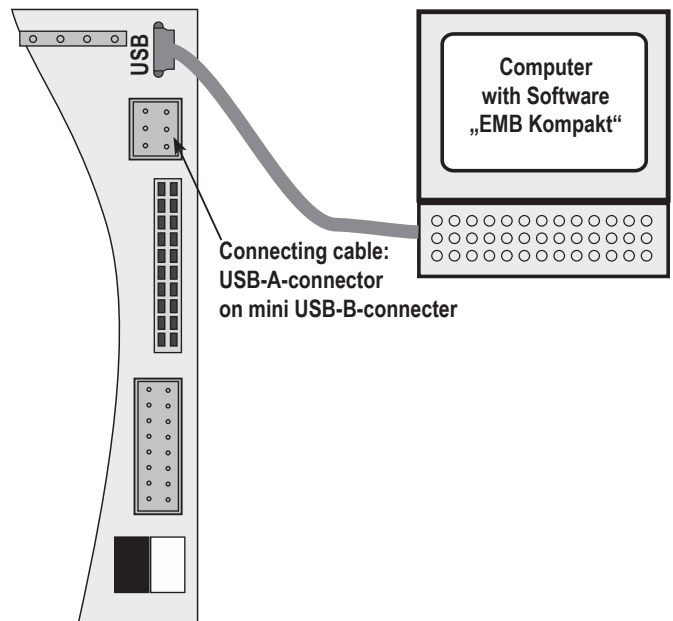

Connecting cable:  
USB-A-connector  
on mini USB-B-connector

### Program Handling

The user interface of the program allows fast and intuitive working. A HELP-function provides all necessary information.



The Central EMB 7300 was tested in the default setting (factory setting) by VdS. Changes to the central configuration can only be performed by the approved installer (only with VdS systems).



Check for proper operation after each configuration of the Control Unit. We cannot assume liability for faults as a result of an incorrect system configuration and must exclude all warranty claims.

**Functions of the license-free software version**

The following overview lists the functions that are available for free on version VIEW. We expressly reserve the right to make additions and alterations.

- Setting ventilation from dead-man mode to latching (OPEN / CLOSE / OPEN and CLOSE)
- Disabling monitoring of the drive line (factory default setting = active)
- Disabling Emergency-OPEN in case of a failure (factory default setting = active)
- Selecting switching threshold of a wind sensor (factory default setting = 5 m/s)
- Setting time-controlled automatic closing (factory default setting = not active)
- Enabling closing in case of power failure (factory default setting = not active)
- Setting acoustic or optical warning signal (requires additional hardware)
- Indicating, saving and printing system status
- Update of firmware

**Functions of the software version subject to license**

The following overview lists the functions that are only available after paid activation of the software. We expressly reserve the right to make additions and alterations.

- Setting service/maintenance date (setting protected by password)
- Setting switch-on delay WIND (factory default setting 20 s)
- Setting switch-off delay WIND (factory default setting 20 min)
- Restoring the switching state before wind/rain control
- Disabling drive retriggering function at SHEV Emergency-OPEN
- Deactivating the line for break-glass units
- Deactivating the line for smoke detectors (or triggering of the external fire alarm system)
- Fire alarm system function for smoke detector line
- Smoke detector release overrides Emergency-CLOSE
- Drive line(s) cut-off time (factory default setting 300 s)
- Drive run direction in case of alarm / Emergency-OPEN (factory default setting = open)
- Emergency-OPEN button in deadman mode
- Line-related Emergency-OPEN in case of drive line failure (only reasonable with version 0102)
- Setting / selecting functions of relay plug-in card REL 65
- Integration into digital networks (LON or KNX) including network options

**INSTALLATION STEP 8: Enabling operation/completing installation**

Before the installer is allowed to enable the operation of the Control Unit, the complete performance range of the system must be checked with utmost care. The chapter „Troubleshooting and Repair“ provides support for the localisation of possible faults and malfunctions.

On the last page you find an overview of all external connections where the current assignments can be entered.

Modifications of the system using the system software should take place after the complete installation of the Control Unit and all components being connected. When required, the system configuration and status can be saved or printed using the system software. In the case of faults or malfunctions of system components it might also be necessary to thoroughly check the system configuration (computer to be connected using system software).



For safety reasons the Control Unit is supplied with „deadman“ pre-setting for ventilation. You require the software for switching over to „latching“. It is absolutely necessary to ensure that all safety-relevant requirements for the „latching“ mode are guaranteed according to the information provided by the manufacturers of the connected opening components.



Before changing the operating mode check and pay attention to danger zones at the window!

SHEV systems require a logbook, in which all important master data have to be entered prior to operation enable and all operational events during the period in operation. The logbook is part of the system documents and must be stored and available to authorized staff at all times.



Follow the instructions in the chapter „Safety instructions“.

We advise to perform an insulation measurement of the cable network before enabling operation of the plant and to keep a written record of this test.



Depending on the storage period the back-up accumulators require some time to be fully charged. Therefore, bridging time (see chapter „Data sheet“) for the power failure might not be ensured after connecting the back-up accumulators and the back-up accumulators first need some charging time in mains operation to reach the maximum charge status (min. 8 hours).



The Control Unit must not be enabled for operation unless all system components work properly. This also applies to system components that do not come under our producer responsibility or whose installation had not been commissioned but are still components of the SHEV system. Upon completion of the installation, all functions of the Control Unit must be checked for correct functionality with utmost care. Even if there is no fault indication this does not mean that all components function faultlessly.

Provided that the factory default configuration has been changed using the system software, all alterations have to be taken into account in the operating manual. It might be required to prepare an operating manual for non-specialist users that is easy to follow and well understandable.



In case of fire the system saves lives. Therefore immediately remedy or have any fault or mal-function remedied by specialists!

## Troubleshooting and Repair

All functions and system components that are important for the SHEV operation are constantly monitored for faults. A fault indication signals the type of fault and, respectively, possible errors when connecting system components (such as back-up accumulators, detectors, drives) during commissioning of the Control Unit.



The configuration of the Control Unit using the software has a significant impact on the functionality of the individual system components. Therefore, it might be necessary to connect a computer provided with the system software for precise testing.

The overview below details some of the possible faults and problem cases and their causes. „Indicator B” means the green operating indicator which does not light up in case of a fault. The yellow “Indicator S” signals the type of fault. You find a list of all indicators in chapter „Indicator and Control elements”.

Fault / Mal-function	Possible cause and their solution
No indicator lights up	<ul style="list-style-type: none"> <li>no power supply available or fuse F1 / F2 defective</li> </ul>
Indicator „S” flashes	<ul style="list-style-type: none"> <li>check power supply connection</li> </ul>
Indicator „S” blinks quickly	<ul style="list-style-type: none"> <li>back-up accumulators are not correctly connected or are not charged</li> </ul>
Indicator „S” has steady light	<ul style="list-style-type: none"> <li>open circuit or short circuit in manual fire alarm</li> <li>faulty power monitoring</li> </ul>
Indicator „S” blinks slowly	<ul style="list-style-type: none"> <li>open circuit or short circuit in smoke detector line</li> <li>faulty power monitoring</li> </ul>
Indicator „S” blinks 2 times	<ul style="list-style-type: none"> <li>service required (indicator „B” (green) lights up!)</li> </ul>
Indicator „S” blinks 3 times	<ul style="list-style-type: none"> <li>fault bus module (e.g. radio module)</li> </ul>
Indicator „S” blinks 4 times	<ul style="list-style-type: none"> <li>open circuit or short circuit in drive line 1</li> <li>faulty power monitoring</li> </ul>
Indicator „S” blinks 5 times	<ul style="list-style-type: none"> <li>only drive line 2, cause of fault analogue to drive line 1</li> </ul>
Indicator „S” blinks 6 times	<ul style="list-style-type: none"> <li>Emergency-CLOSE button (break-glass unit) does not work properly and/or is not recognized</li> </ul>
Drives do not respond	<ul style="list-style-type: none"> <li>check fuse F2 / F3</li> <li>check drive connections based on assembly instructions</li> <li>or, if the indicators (red / green) do not respond: check ventilation control</li> </ul>
Drives run incorrectly	<ul style="list-style-type: none"> <li>The indicators for the drive run direction (red / green) must comply with the actual running direction. Otherwise swap connections on terminal 1 and 2</li> <li>check drive connections based on their installation instructions</li> </ul>
Signal REL65 is not recognized	<ul style="list-style-type: none"> <li>check relay plug-in card REL 65 for correct installation and connection</li> </ul>



The system software offers the possibility to check the system behaviour in detail. Even when contacting our support team on the phone it is helpful to have available a computer with the system software installed.

## Fuses

Control Unit version			
<b>EMB 7300</b> <b>2,5A-0101</b>	<b>F1</b> 3,15 AT (accumulators)	<b>F2</b> 3,15 AT (drives)	<b>F3</b> 3,15 AT (primär)

Control Unit version			
<b>EMB 7300</b> <b>5A-0102</b>	<b>F1</b> 5 AT (accumulators)	<b>F2</b> 6,3 AT (drive 1)	<b>F3</b> 6,3 AT (drive 2)
<b>EMB 7300</b> <b>10A-0102</b>	<b>F1</b> 10 AT (accumulators)	<b>F2</b> 10 AT (drive 1)	<b>F3</b> 10 AT (drive 2)
<b>EMB 7300</b> <b>20A-0102</b>	<b>F1</b> 25 AT (accumulators)	<b>F2</b> 10 AT (drive 1)	<b>F3</b> 10 AT (drive 2)

Control Unit version			
<b>EMB 7300</b> <b>5A-0101</b>	<b>F1</b> 5 AT (accumulators)	<b>F2</b> 6,3 AT (drives)	
<b>EMB 7300</b> <b>10A-0101</b>	<b>F1</b> 10 AT (accumulators)	<b>F2</b> 10 AT (drives)	

# Indicator and Control elements

## Position in the Control Unit

The indicators and control elements (switches) are in the same position on all EMB 7300 versions. Only the number of ventilation lines varies. The versions EMB 7300 5A-0102, EMB 7300 10A-0102, EMB 7300 20A-0102 have two sets of indicators and control elements for the drive control (LT 1 and LT 2).

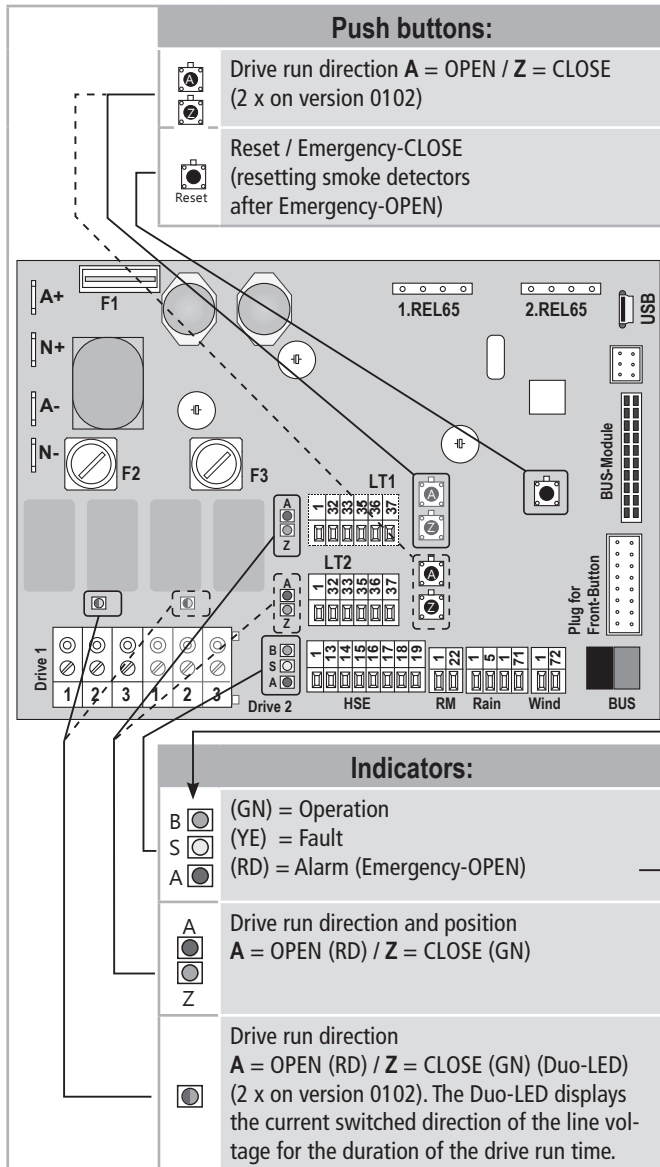

## Meaning of the Displays (overview)

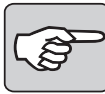

Basically, the green indicator „B” signals that the Control Unit works properly. A yellow indicator „S” lighting up signals a fault to be eliminated immediately. Since the type of fault signal into the break-glass units may differ from the fault indicator „S” in the Control Unit, always pay regard to the indicators in the Control Unit for exact troubleshooting.

Drive run direction	
<b>Drives</b> <b>OPEN</b> <input checked="" type="checkbox"/> RD *) 	<b>Drives</b> <b>CLOSE</b> <input checked="" type="checkbox"/> GN *) 
*) The Duo-LED only lights up for the duration of the drive run time.	

Alarm activation / Emergency-OPEN	
<b>Mains operation</b> Emergency-OPEN B <input checked="" type="checkbox"/> on (GN) S <input checked="" type="checkbox"/> out (YE) A <input checked="" type="checkbox"/> on (RD)	<b>Accumulator operation (power failure)</b> Emergency-OPEN B <input type="checkbox"/> off S <input checked="" type="checkbox"/> flashes (YE) A <input checked="" type="checkbox"/> on (RD)

Faults		
Indicator	Meaning	Note
B <input type="checkbox"/> off S <input checked="" type="checkbox"/> flashes	Power failure / accumulator operation	
B <input type="checkbox"/> off S <input checked="" type="checkbox"/> fast blinking	Accumulator fault	
B <input type="checkbox"/> off S <input checked="" type="checkbox"/> on	Break-glass unit fault	
B <input type="checkbox"/> off S <input checked="" type="checkbox"/> slow blinking	Smoke detector fault	
B <input type="checkbox"/> off S <input checked="" type="checkbox"/> 2 x blinking	Service required	Licence software required for setting
B <input type="checkbox"/> off S <input checked="" type="checkbox"/> 3 x blinking	Fault bus module (e.g. radio module)	
B <input type="checkbox"/> off S <input checked="" type="checkbox"/> 4 x blinking	Fault drive line 1	
B <input type="checkbox"/> off S <input checked="" type="checkbox"/> 5 x blinking	Fault drive line 2	only on Control Unit version 0102
B <input type="checkbox"/> off S <input checked="" type="checkbox"/> 6 x blinking	Fault Emergency-CLOSE button	Persistent contact
B <input checked="" type="checkbox"/> on S <input checked="" type="checkbox"/> slow blinking A <input checked="" type="checkbox"/>	System was closed via break-glass unit, smoke detectors are still activated.	

### Notes

B  GN = green  
 S  YE = yellow  
 A  RD = red

only available on Control Unit version  
 EMB 7300 5A-0102  
 EMB 7300 10A-0102  
 EMB 7300 20A-0102

LED display for break-glass unit (HSE)	
Display	State
B <input type="checkbox"/> on S <input type="checkbox"/> off A <input type="checkbox"/> off	Normal operation
B <input type="checkbox"/> on S <input type="checkbox"/> off A <input type="checkbox"/> on	Emergency-OPEN / alarm (mains operation)
B <input type="checkbox"/> off S <input type="checkbox"/> flashes A <input type="checkbox"/> on	Emergency-OPEN / alarm (back-up accumulators mode)
B <input type="checkbox"/> off S <input type="checkbox"/> flashes A <input type="checkbox"/> off	power failure (highest priority)
B <input type="checkbox"/> off S <input type="checkbox"/> on A <input type="checkbox"/> off *	Fault to break-glass unit lines  * depending on the configuration „Emergency-OPEN Troubleshooting“ OPEN or CLOSE
B <input type="checkbox"/> off S <input type="checkbox"/> on A <input type="checkbox"/> off *	Fault to smoke detector lines  * depending on the configuration „Emergency-OPEN Troubleshooting“ OPEN or CLOSE
B <input type="checkbox"/> off S <input type="checkbox"/> blinks slowly A <input type="checkbox"/> off *	Fault in motor-line 1  * depending on the configuration „Emergency-OPEN Troubleshooting“ OPEN or CLOSE
B <input type="checkbox"/> off S <input type="checkbox"/> blinks slowly A <input type="checkbox"/> off *	Fault in motor-line 2  * depending on the configuration „Emergency-OPEN Troubleshooting“ OPEN or CLOSE
B <input type="checkbox"/> off S <input type="checkbox"/> blinks slowly A <input type="checkbox"/> off	Fault at Emergency-CLOSE button
B <input type="checkbox"/> off S <input type="checkbox"/> blinks quickly A <input type="checkbox"/> off	Back-up accumulators fault (lowest priority)
B <input type="checkbox"/> on S <input type="checkbox"/> 2x blinking A <input type="checkbox"/> off	Maintenance expired
B <input type="checkbox"/> on S <input type="checkbox"/> off A <input type="checkbox"/> off	Rain active
B <input type="checkbox"/> on S <input type="checkbox"/> off A <input type="checkbox"/> off	Wind active
B <input type="checkbox"/> on S <input type="checkbox"/> off A <input type="checkbox"/> off	Wind and rain active

B <input type="checkbox"/> Operation	 The functionalities of the external LED outputs are configurable.
S <input type="checkbox"/> Fault	
A <input type="checkbox"/> Emergency-OPEN LED display	

## Maintenance and Modification

To ensure continuous function and safety of the complete system periodic maintenance by a specialist company is required at least once a year (as mandated by law for smoke and heat exhaust systems). Operational readiness must be checked regularly, at least once a month.



After opening of the system housing voltage carrying parts are exposed! Each time, before performing maintenance work or making a modification of the structure (e.g. replacement of the window drive), the mains voltage and – as far as available – the accumulators must be completely disconnected and secured against unintentional reactivation (lock in separation mode).

The information provided in these instructions for the maintenance must be observed. Malfunctions must be remedied immediately. Only spare parts made by the manufacturer may be used. Between maintenance intervals the operator shall carry out or order a visual inspection at least once and document it in writing in the log book. We recommend a maintenance contract with a specialist company authorized by the manufacturer. A sample maintenance contract can be downloaded from the homepage of

**FIRM AUMÜLLER AUTOMATIC GMBH**  
([www.aumueller-gmbh.de](http://www.aumueller-gmbh.de)).

### What has to be serviced?

- Check all **connections** (also the ones in the Control Unit) for tightness and for possible damage.
- Check all **fuse links**.
- Check charge level and installation date of back-up **accumulators** and exchange the accumulators, if necessary (accumulators must be exchanged 4 years after installation). Note down the exchange date on the accumulator. Dispose of removed accumulators in conformity with legal requirements.
- Check **drive control** for proper function. Also check drive run directions. If the actuation is correct but the drive is still not working properly, pay regard to the assembly and maintenance instructions of the drive manufacturer.
- Check all **break-glass units** and ventilation buttons for functionality (do the drives move in the direction indicated on the buttons?)
- Check all **smoke detectors** according to manufacturer's instructions using test gas.
- Remove dirty or faulty **detectors** and send them to the manufacturer for repair or cleaning.
- When connecting **wind and rain sensors** check for proper functionality of the sensors, readjust the wind response threshold, if necessary.
- Check the **configuration** with our system software and test if the system works with the stored configuration.

The service instructions for the connected components are decisive for their maintenance.

## Measuring points for measurement according to EN 60204 / VDE 0113

A measurement according to EN 60204 / VDE 0113 is required when the system is set up / commissioned. This measurement must be carried out by a qualified specialist. We have prepared the released measuring points for you in the following table.

We are no longer enclosing the protocol that was previously enclosed, but the measurement for quality assurance will continue to take place in our company and will be marked with a stamp in the attachment.

**Measuring points:  
Compact Control Unit EMB7300 - 2,5 A**

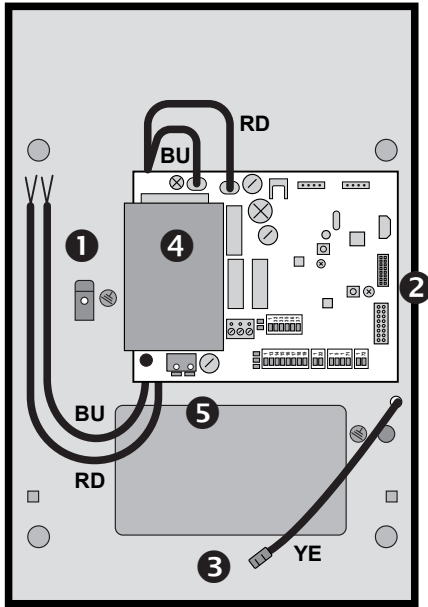

Protective conductor continuity measurement is carried out between:

Based on the feed terminal 1 and the following measuring points:

- Mounting plate (mounting screw) 2
- Housing door grounding point 3
- PSU case (housing of the power supply) 4
- A suitable grounding point outside the Control Unit

Insulation measurement of terminals L and N 5 against the protective conductor 1

**Measuring points:  
Compact Control Unit EMB7300 - 5 A**

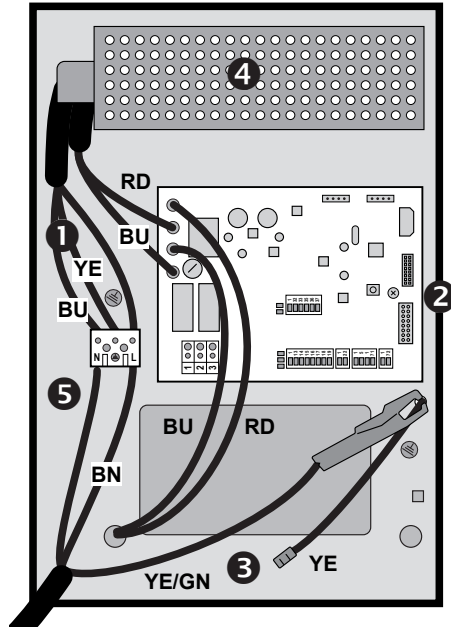

Protective conductor continuity measurement is carried out between:

Based on the feed terminal 1 and the following measuring points:

- Mounting plate (mounting screw) 2
- Housing door grounding point 3
- PSU case (housing of the power supply) 4
- A suitable grounding point outside the Control Unit

Insulation measurement of terminals L and N 5 against the protective conductor 1

The residual voltage measurement on the power supply: Terminal L against terminal N 5

**Measuring points: Compact Control Unit EMB7300 - 10 A / EMB7300 - 20 A**

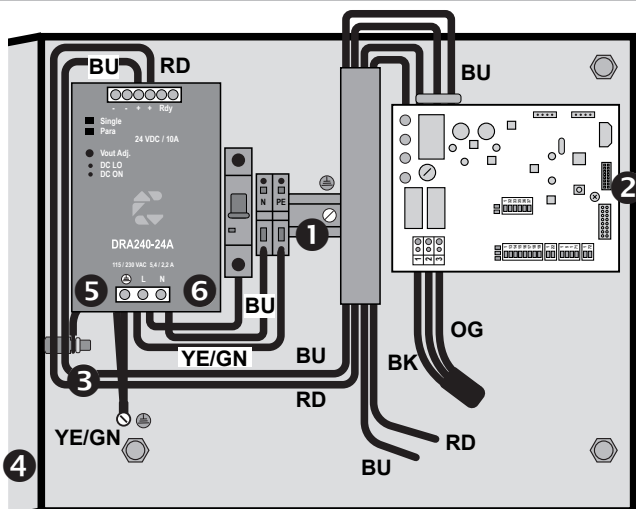

Protective conductor continuity measurement is carried out between:

Based on the feed terminal 1 and the following measuring points:

- Mounting plate (mounting screw) 2
- Housing grounding point 3
- Housing door grounding point 4
- Power supply connection terminal for protective conductor 5
- A suitable grounding point outside the Control Unit

Insulation measurement of terminals L and N 6 against the protective conductor 1

The residual voltage measurement on the power supply: Terminal L against terminal N 6

## Important maintenance information

- While working in the Control Unit the workplace must be secured against unauthorized access.
- The specialists performing the maintenance work are solely responsible for the maintenance.
- For smoke and heat exhaust systems a log book must be kept in which the maintenance work must be documented. Special attention must be paid to operating events (e.g. repeatedly occurring malfunctions) which may be recorded.
- These installation and operating instructions are part of the maintenance documents. The control device may be maintained only by considering the information provided therein. This affects also system supplements and the exchange of components. A separate maintenance protocol should be prepared and filed with the maintenance documents.
- Only original parts may be used. Otherwise the warranty obligation and product liability of the manufacturer shall no longer apply.
- For the maintenance of individual system components the installation and maintenance instructions of the manufacturer of these components shall be binding. If they are not available, they must be requested from the manufacturer. In case special maintenance instructions are prescribed (e.g. for natural smoke and heat exhaust ventilators pursuant to EN 12101-2), they must also be on hand.



The system configuration must be inspected and recorded each time maintenance work is performed. The next maintenance date can only be scheduled with the fee-based licensed software and protected against unauthorized access by using a password. The maintenance date is then signaled by the fault indicator "S" by flashing twice.

## Demounting and dismantling

The Control Unit shall be stored only in locations protected from moisture, severe contamination and temperature fluctuations (not beyond 30°C). The packaging shall not be removed until the control system is to be installed. Disconnect the accumulators and store them separately after the control device has already been in operation.

**It is imperative that the following is observed for the storage of the accumulators:**



Keep the storage time of lead-acid accumulators short, because the accumulators discharge as time passes. At the latest after seven months in storage accumulators must be recharged. Use either a suitable accumulator charger or connect the accumulators to an EMB Control Unit and supply same with mains voltage. In both cases the charging time requires a minimum of 8 hours (depending on the discharge).

In case the Control Unit is permanently decommissioned the statutory provisions for the destruction, recycling and disposal shall be observed. The control device contains plastic, metal, electrical components and accumulators. Replaced accumulators contain highly toxic pollutants and may therefore only be disposed of at collection points prescribed by the legislator.



Before dismantling the Control Unit separate same completely from the mains!

## Warranty and Customer service

In principal our following term are applicable:

„General Terms for the Supply of Products and Services of the Electrical Industry (ZVEI)“.  
„Terms for the used software“.

The warranty corresponds with legal provisions and applies to the country in which the product has been acquired.

The warranty includes material and manufacturing defects incurred during normal use.

The warranty period for delivered material is twelve months.

Warranty and liability claims for personal injuries or material damages are excluded, if caused by one or more of the following:

- Improper use of the product.
- Improper installation, commissioning, operation, maintenance or repair of the product.
- Operating the product by defect and improper installed or not functioning safety and protection devices.
- Ignoring instructions and installation requirements in these instructions.
- Unauthorized constructional modifications at the product or accessories.
- Disaster situations due to effects of foreign bodies and Acts of God.
- Wear and tear.

Point of contact for possible warranty claims or for repair parts or accessories is the responsible branch office or the responsible person at

**Firm AUMÜLLER Aumatic GmbH.**

Contact data are available at our homepage

([www.aumueller-gmbh.de](http://www.aumueller-gmbh.de))

## Liability

We reserve the right to change or discontinue products at any time without prior notice. Illustrations are subject to change. Although we take every care to ensure accuracy, we cannot accept liability for the content of this document.

## Disposal

According to the European Directive 2012/19 / EU on Waste Electrical and Electronic Equipment (WEEE) and its transposition into national law, obsolete electrical appliances must be collected separately and sent for environmentally friendly recycling.

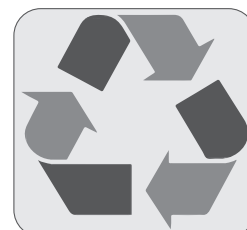

## Overview on all external connections to be completed

Pay regard to the individual connection diagrams in this manual for the position of the respective terminals as detailed for the different Control Unit versions.

Terminals		Remark
Drive 1	CLOSE + OPEN - <b>1</b>	
	- + <b>2</b>	
	Line monitoring <b>3</b>	
Drive 2 only version 0102	CLOSE + OPEN - <b>1</b>	
	- + <b>2</b>	
	Line monitoring <b>3</b>	
Ventilation 1	COM <b>1</b>	
	Buttons OPEN <b>32</b>	
	CLOSE <b>33</b>	
	Indicators COM <b>35</b>	
	OPEN <b>36</b>	
	CLOSE <b>37</b>	
Ventilation 2 only version 0102	COM <b>1</b>	
	Buttons OPEN <b>32</b>	
	CLOSE <b>33</b>	
	Indicators COM <b>35</b>	
	OPEN <b>36</b>	
	CLOSE <b>37</b>	
Break-glass unit	Buttons COM <b>1</b>	
	Emergency-OPEN <b>13</b>	
	ZU <b>14</b>	
	COM - <b>15</b>	
	Indicators Emergency-OPEN + <b>16</b>	
	+ <b>17</b>	
	Operation + <b>18</b>	
	Fault + <b>19</b>	
Smoke detectors or external fire alarm system	<b>1</b>	
	+ <b>22</b>	
Rain sensor	- <b>1</b>	
	+ <b>5</b>	
	- <b>1</b>	
	<b>71</b>	
Wind sensor	- <b>1</b>	
	<b>72</b>	
1. REL 65 (optional)	<b>1</b>	
	<b>2</b>	
	COM <b>3</b>	
2. REL 65 (optional)	<b>1</b>	
	<b>2</b>	
	COM <b>3</b>	





## Certificate and Declaration of Conformity

We declare under our sole responsibility that the product described under "Data sheet" is in conformity with the following directives:

- 2014/30/EU  
Directive relating to Electro-Magnetic Compatibility
- 2014/35/EU  
Low voltage Directive



Technical file and declaration at firm:

**AUMÜLLER AUMATIC GmbH**  
Gemeindewald 11  
D-86672 Thierhaupten

Ramona Meinzer  
Managing Director (Chairman)

### Note:

The proof of the application of a quality management system is for company:

**AUMÜLLER AUMATIC GmbH**  
according to the certification basis **DIN EN 9001** as well the "Declaration of Incorporation and Conformity" can be accessed via the QR code or directly on our homepage:  
**(www.aumueller-gmbh.de)**



## The VdS approval includes the following Control Units:

- EMB 7300 2,5A** without SHEV button
- EMB 7300 2,5A** with orange SHEV button
- EMB 7300 5A** without SHEV button
- EMB 7300 5A** with orange SHEV button
- EMB 7300 10A**
- EMB 7300 20A**

### Translation of the original instructions (German)

#### Important note:

We are aware of our responsibility, which is why we present life-supporting and value-preserving products with greatest possible conscientiousness. Although we make every effort to ensure that the data and information are as correct and up-to-date as possible, we still cannot guarantee that they are free from mistakes and errors.

All information and data contained in this document are subject to alterations without prior notice. Distribution and reproduction of this document as well as the use and disclosure of its content is not authorized unless expressly approved. Offenders will be held liable for the payment of damages. All rights reserved in the case of a patent award or utility model registration.

Basically the General Terms and Conditions of **AUMÜLLER AUTOMATIC GmbH** apply to all offers, supplies and services.

The publication of these assembly and commissioning instructions supersedes all previous editions.

AUMÜLLER AUMATIC GMBH  
Gemeindewald 11  
86672 Thierhaupten

Tel. +49 8271 8185-0  
Fax +49 8271 8185-250  
info@aumueller-gmbh.de

**[www.aumueller-gmbh.de](http://www.aumueller-gmbh.de)**

9000007401\_V2.6\_KW40.2024